

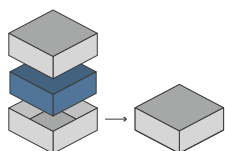

ORGANIZER - COMPATIBLE WITH PUERTO RICO - 2011 EDITION



Designed to fit into the game box; flush closure is guaranteed. Progettato per inserirsi all'interno della scatola del gioco; garantisce chiusura a filo*

90



Pieces to assemble
Pezzi da assemblare

21 x 29.2 x 5.6 cm



Size of assembled organiser
Dimensioni organizer assemblato

ORGANIZER CAPACITY

1x base, with incisions to easily put the various containers back into the box in the right locations; 1x doubloon box, with shutter opening for easy access to parts; 1x PV box, with 3 slots for setup based on the number of players, with guide engravings to insert the right number of pieces; 1x token holder for ships, roles, expansion buildings and large buildings; 1x building box, with 18 slots for each different type of buildings; 1x box for plantations and quarries, with front space for token placement based on the number of players; 1x box for red noble settlers and colonists, with 4 separate boxes for quick setup based on the number of players (internal engravings with guides for the right number of pieces to insert); 1x box for barrels, with 5 separate hostings and shutter opening for easy access to the pieces. 1x base, con incisioni per rimettere nella scatola con facilità i vari contenitori; 1x portadoblioni, con apertura a saracinesca per accesso facilitato ai pezzi; 1x scatola PV, con 3 alloggiamenti per il setup in base al numero di giocatori, con incisioni guida per inserire il giusto numero di pezzi; 1x portatoken navi, ruoli, edifici espansioni e edifici grandi; 1x scatola per edifici, con 18 alloggiamenti per i vari tipi di edifici; 1x scatola per piantagioni e cave, con spazio anteriore per piazzamento token in base al numero di giocatori; 1x scatola per coloni e pedine nobili rosse, con 4 contenitori interni separati per setup rapido in base al numero di giocatori (incisioni interne con guida per il giusto numero di pedine da inserire); 1x scatola per barili, con 5 alloggiamenti separati ed apertura a saracinesca per accesso facilitato ai pezzi.

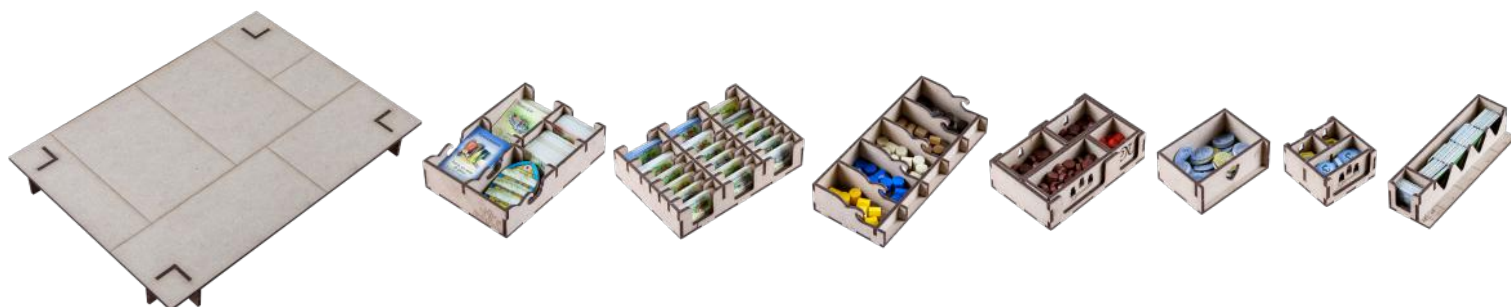

* Any doubt?
Check out our FAQ page
or download the digital
version of the instructions
on our website!

All trademarks and copyrights are the property of their respective owners.
This product is not a toy. Contains small parts that can be swallowed or inhaled. 14+

thedictroyers.com



[/thedictroyers](https://www.facebook.com/thedictroyers)



[/thedictroyers](https://www.instagram.com/thedictroyers)



info@thedictroyers.com





ORGANIZER - COMPATIBLE WITH PUERTO RICO - 2011 EDITION



TUTORIAL - THE DICETROYERS DICE!

Among the pieces to assemble, you'll find a dice. This is not part of the organizer, but it can be a good starting point to practice!

Tra i materiali da assemblare troverai un dado. Questo componente non fa parte dell'organizer, né del gioco, ma è un ottimo punto di partenza per fare un po' di pratica.

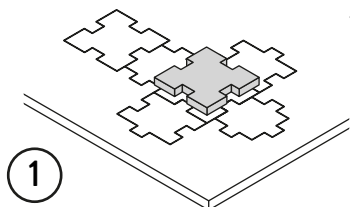

1

Gently take off
all the pieces.
Stacca delicatamente
dal foglio tutti i pezzi.

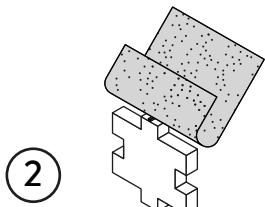

2

If necessary, use sand paper to
smoothen the borders.
Se necessario rifila con carta
vetrata per legno eventuali
imperfezioni dei pezzi.

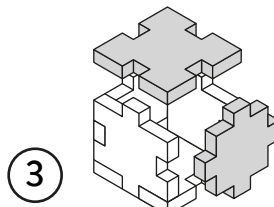

3

Get familiar with
all the pieces
and check the correct assembly
sequence.
Prendi familiarità con tutti
i pezzi, per assicurarti
che la sequenza di assemblaggio sia
corretta.

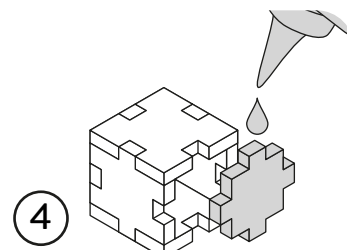

4

Once verified the correct assembly
sequence, just add a small quantity
of PVA glue on every joint.
Dopo aver verificato
la sequenza di assemblaggio
aggiungi una piccola quantità di
colla vinilica su tutti
gli incastri per garantirne
la durata nel tempo.

INSTRUCTIONS

A

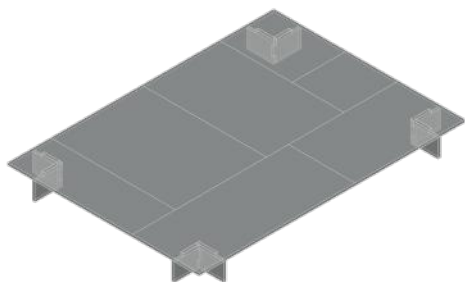
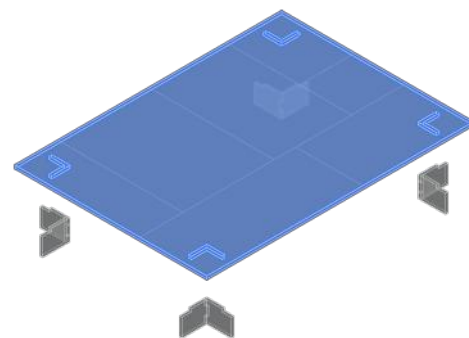
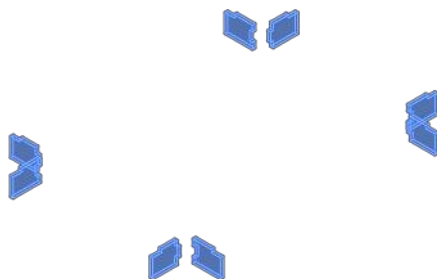
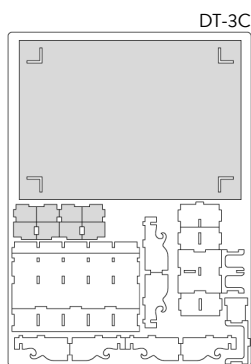

B

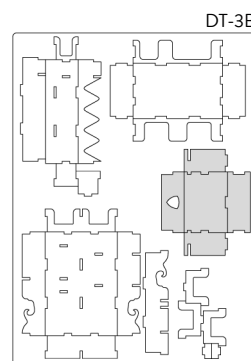

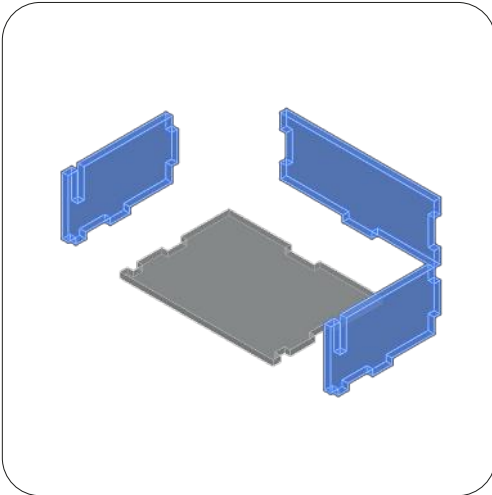

NOTE: Don't use glue on this joint; this piece can be removed during the game. Non usare colla su questo incastro, pezzo rimovibile durante il gioco.

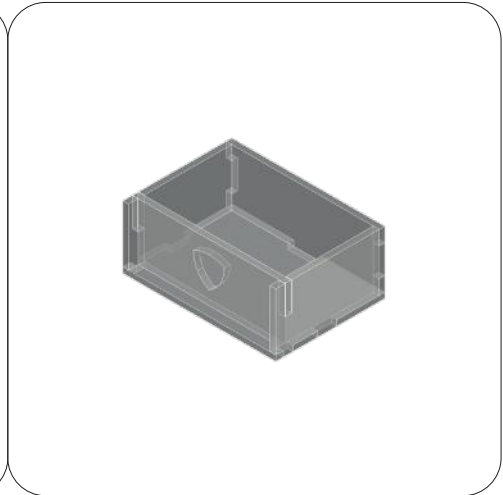

C

DT-3A DT-3C

x2

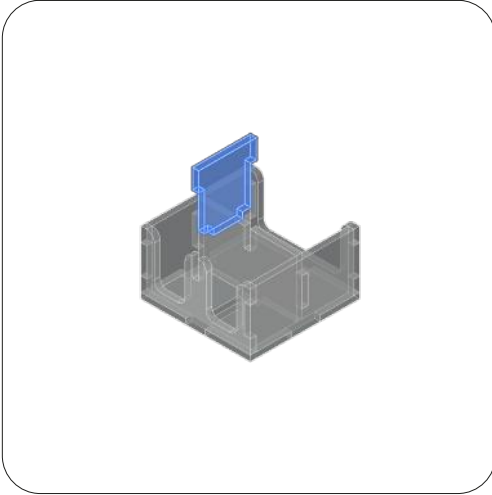
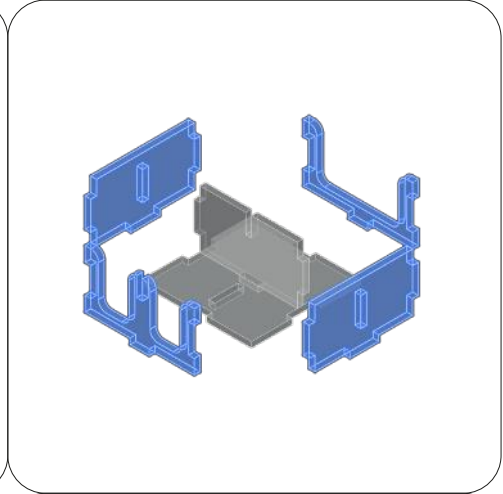
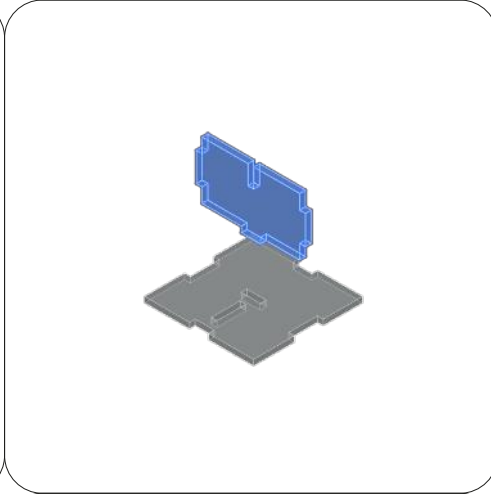
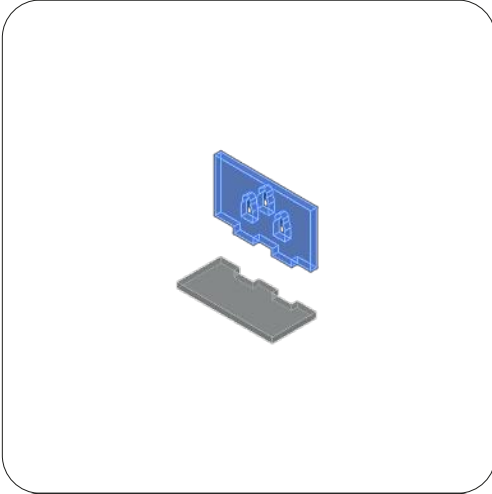

NOTE: Don't use glue on this joint; this piece can be removed during the game. Non usare colla su questo incastro, pezzo rimovibile durante il gioco.

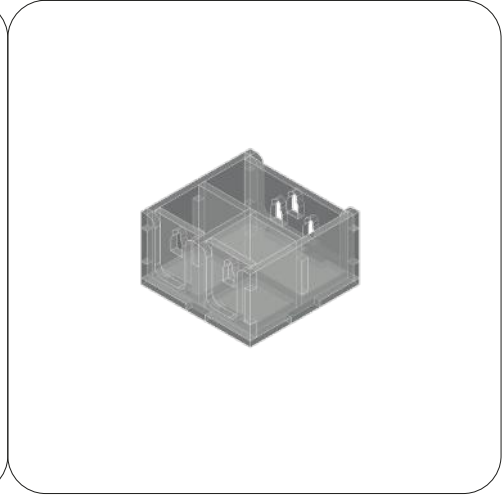



D

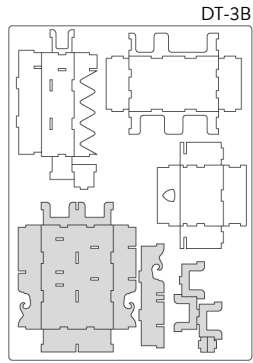

DT-3B

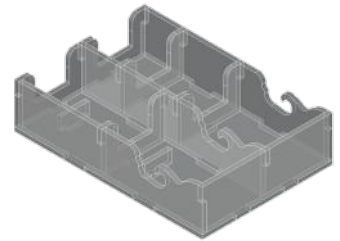
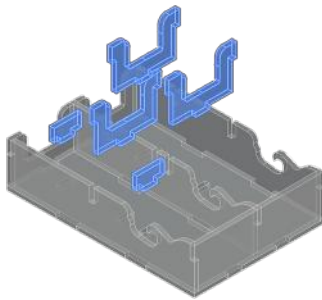
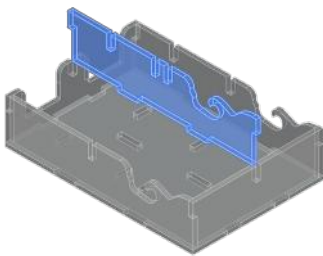
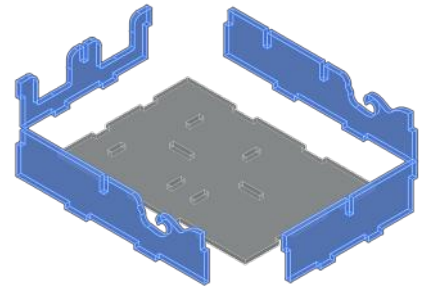

E

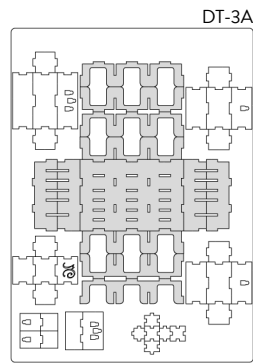

DT-3A

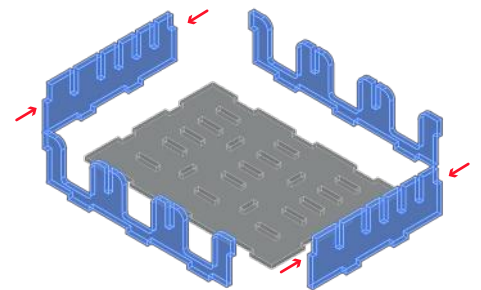

NOTE: Before assembling check carefully the shape of the joints. Controllate bene la forma degli incastri segnalati prima di assemblare il pezzo.

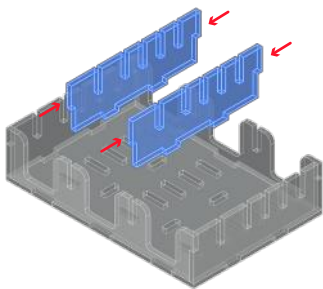

NOTE: Before assembling check carefully the shape of the joints. Controllate bene la forma degli incastri segnalati prima di assemblare il pezzo.

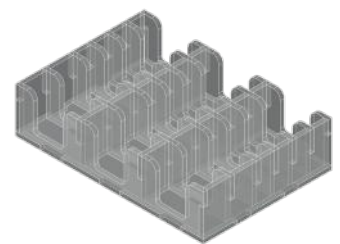
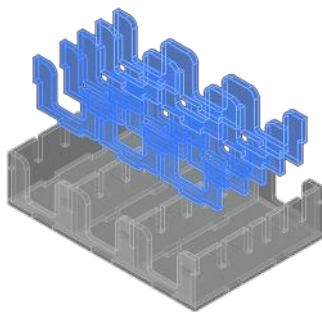

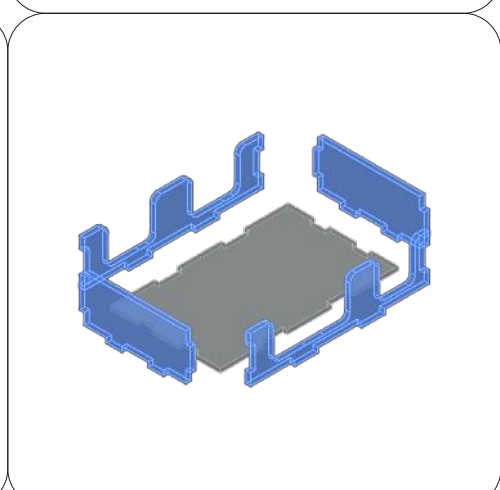
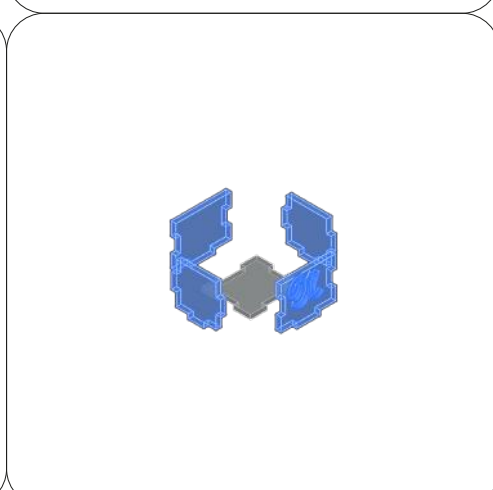
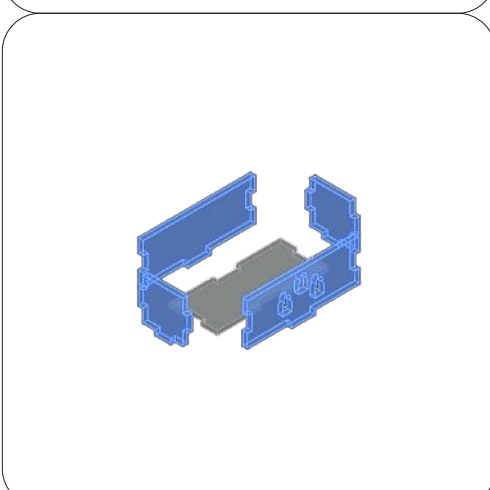
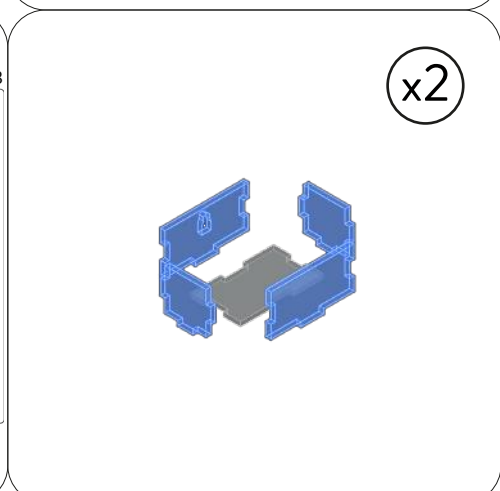
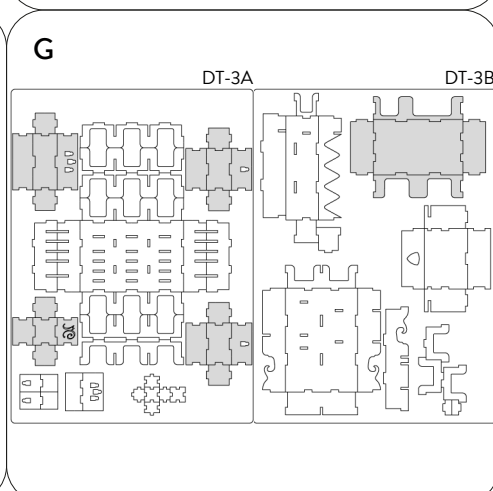
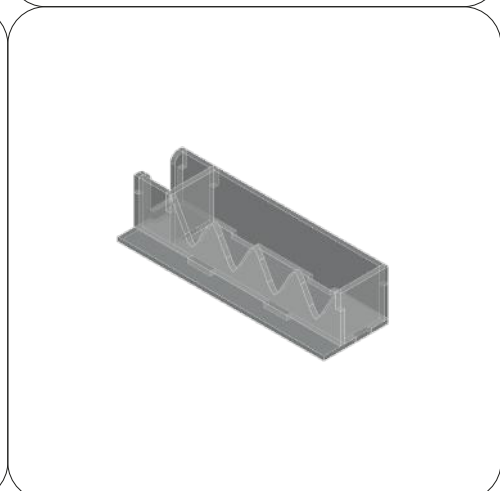
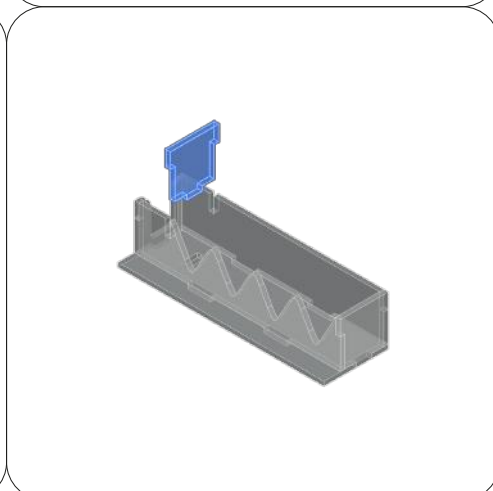
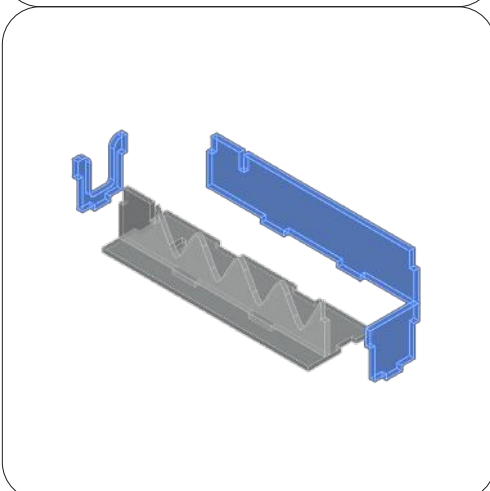
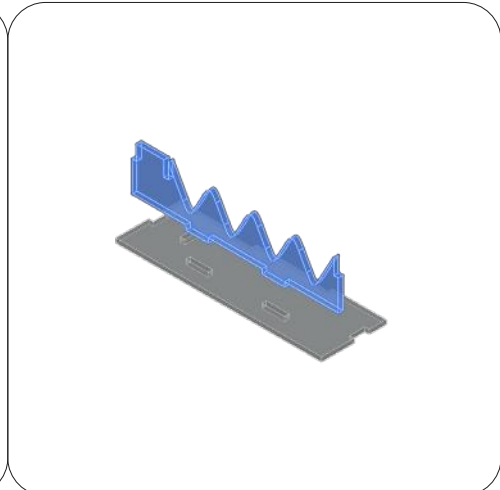
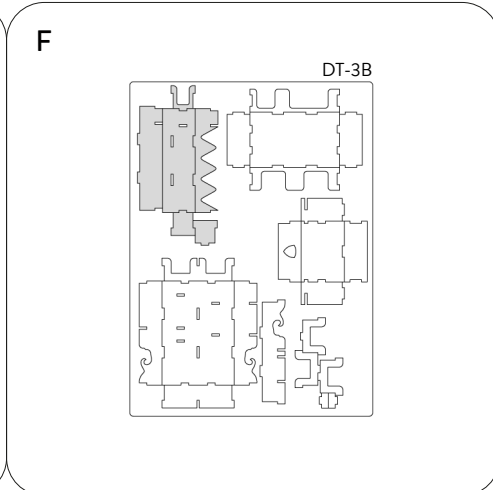
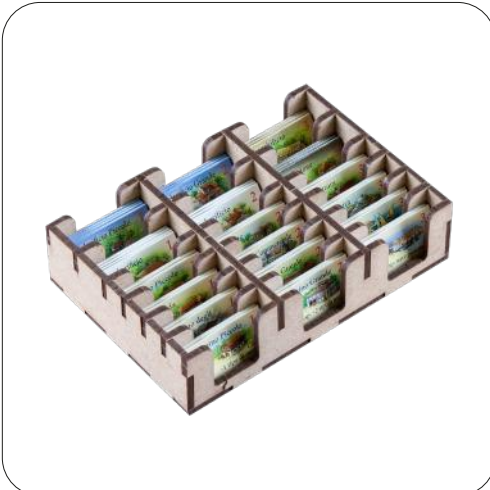

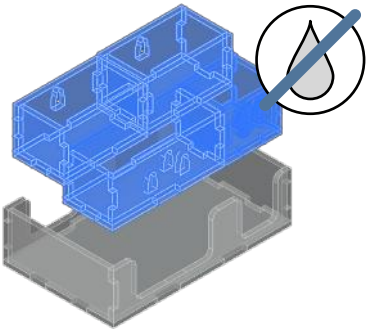

NOTE: Don't use glue on this joint; this piece can be removed during the game. Non usare colla su questo incastro, pezzo rimovibile durante il gioco.

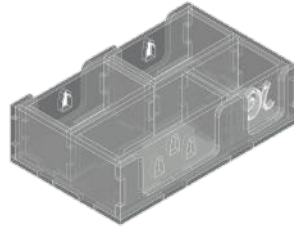

H

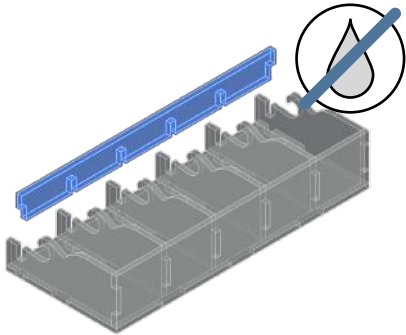
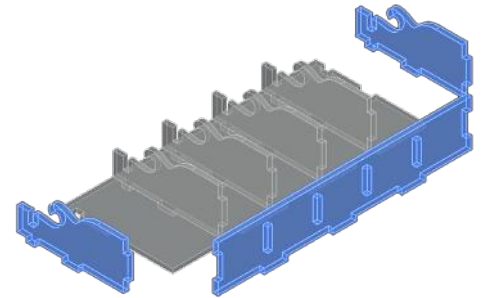
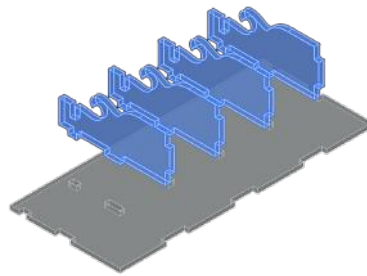
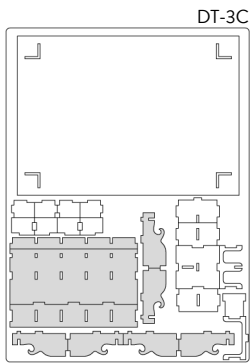

NOTE: Don't use glue on this joint; this piece can be removed during the game. Non usare colla su questo incastro, pezzo rimovibile durante il gioco.

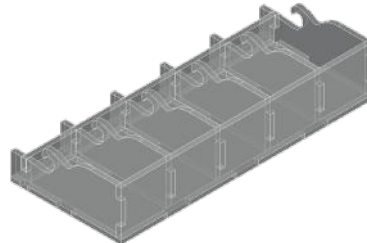

REBOXING SEQUENCE!



Few pieces can fall off their slots. This doesn't affect the setup efficiency. Follow the reboxing sequence to properly store your organizer. We recommend using a h-band to avoid accidental box opening. Don't shake. Qualche componente potrebbe uscire dal suo slot, ma senza muoversi in altri box né inficiare l'efficienza del setupper. Segui la sequenza di reinserimento per riporre nella maniera corretta il tuo organizer. Consigliamo l'utilizzo di una h-band per evitare aperture accidentali. Non scuotere.



All trademarks and copyrights are the property of their respective owners.
This product is not a toy. Contains small parts that can be swallowed or inhaled. 14+